System Architecture and self-configuration in Distributed Camera Networks

Jörg Hähner

Leibniz Universität Hannover, Germany
Inst. f. Systems Engineering
System and Computer Architecture Group

Joint work with Martin Hoffmann, Michael Wittke and Christian Müller-Schloer

© J. Hähner, M. Hoffmann

- Smart Cameras at a glance
- System Architecture
- Node Architecture
- Cooperative Tasks: Spatial partitioning problem
- Conclusion

Distributed Smart Camera System

■ What is it?

■ Each Smart Camera Node:

- Obviously includes a (PTZ) camera
- Local processing resources (CPU, memory, etc.)
- Communication interface to exchange information with other Smart Camera Nodes (e.g. wireless ad-hoc or wired network)

■ Networked Smart Camera Nodes

- Cameras can cooperatively solve surveillance tasks
- Achieve goals that cannot be achieved with a single camera, e.g. wide-area object tracking, multi-view observation
- Efficient and robust coordination and management of (possibly large number of) cameras required



Distributed Smart Camera System

- What is it good for?
 - Unburden human operators from trivial tasks
 - Help to preserve individuals privacy
 - Are superior to centralized surveillance systems
 - No single point of failure

- Where can it be used?
 - Possible application scenario: apron of an airport
 - safety critical, wide area
 - manual camera adjustment is time and cost intensive



System Architecture

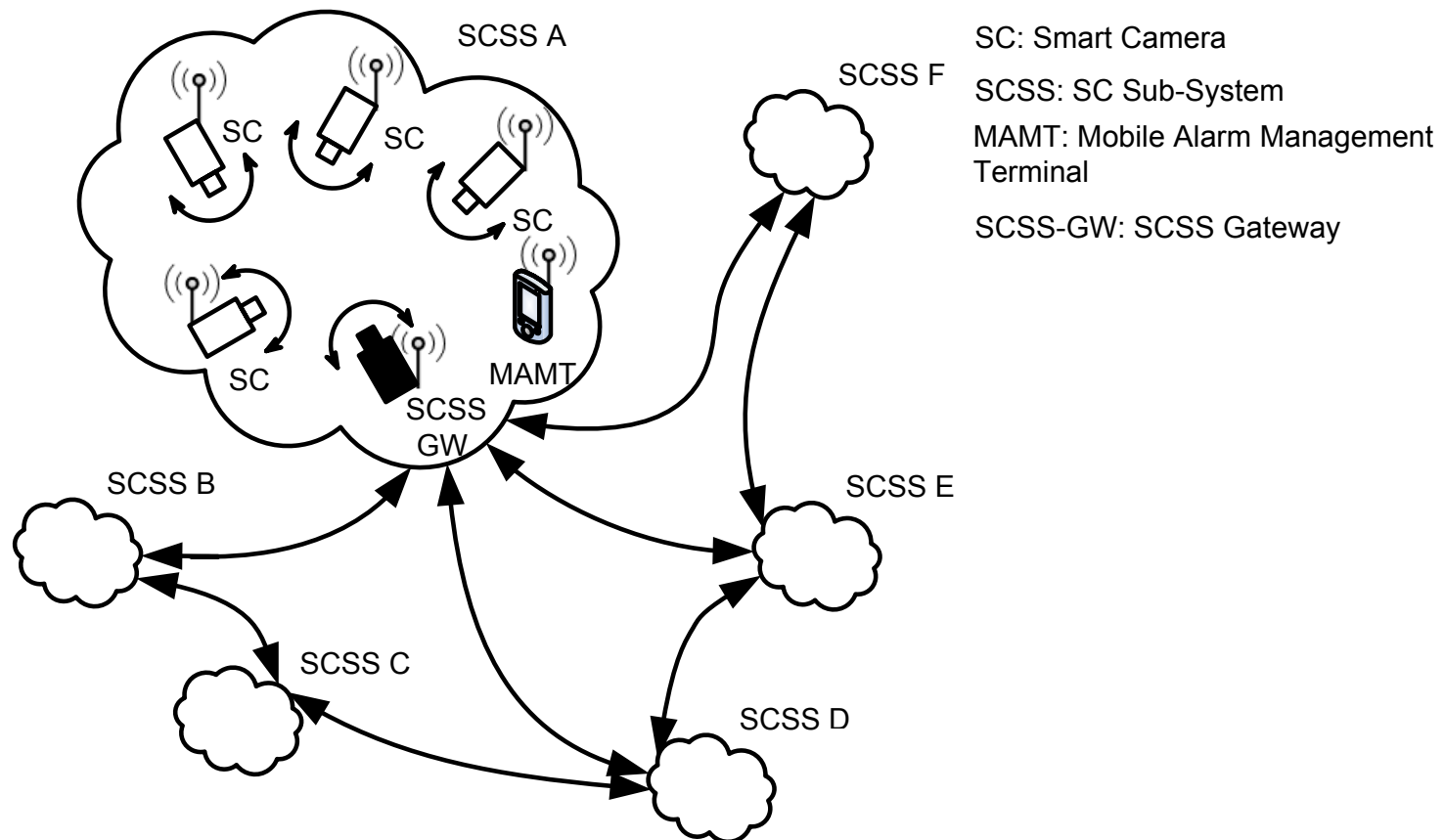

- Smart Camera Sub-system (**SCSS**): spatially adjacent cameras
- **Gateways** in SCSS: interconnect individual SCSS
- Mobile alarm management terminals (**MAMT**): deliver information to the operator

Node Architecture

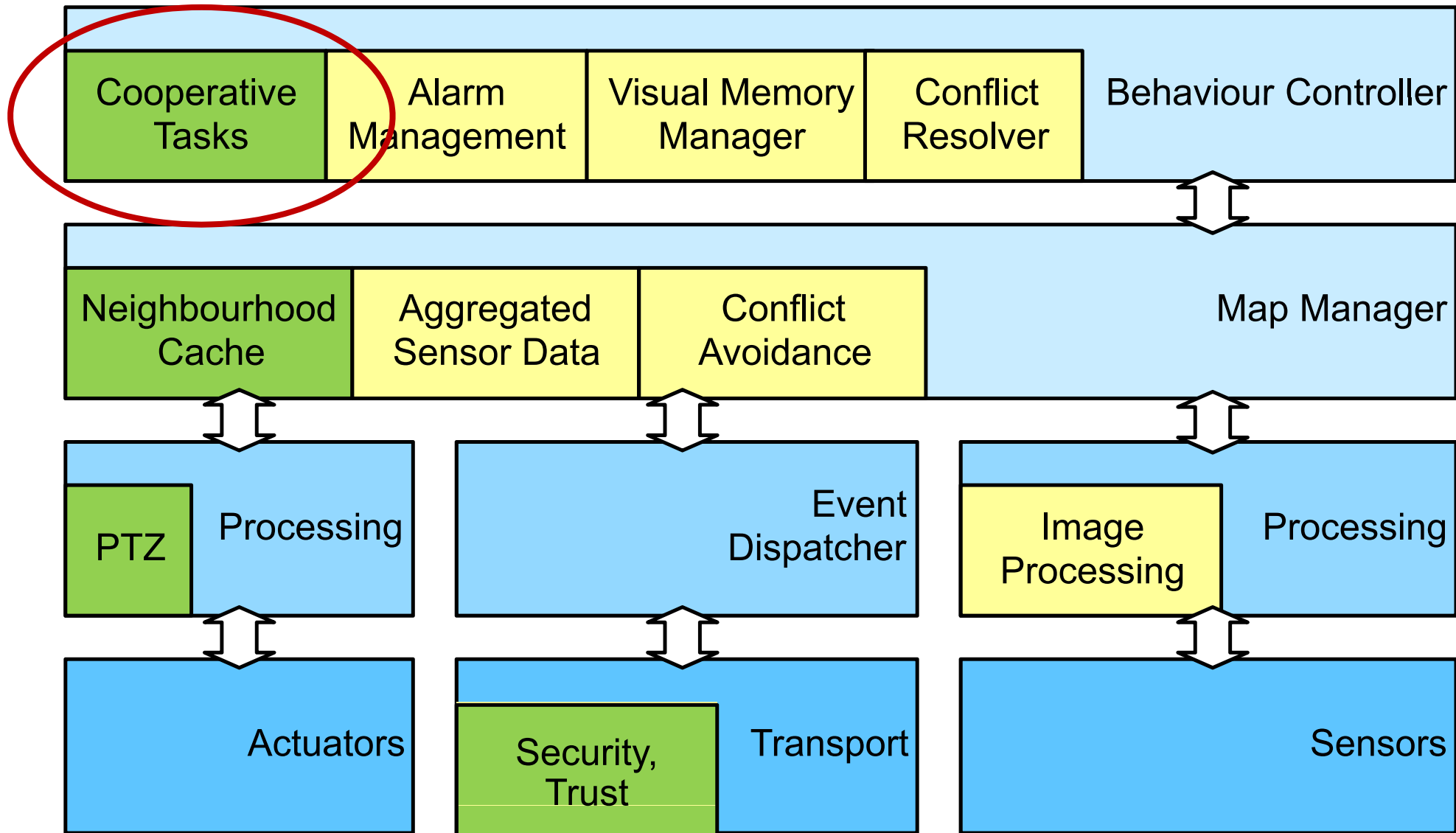

A distributed algorithm for spatial partitioning: ROCAS

- Cooperative Task: **Spatial Partitioning**
- Robust Online Camera Alignment System (ROCAS)

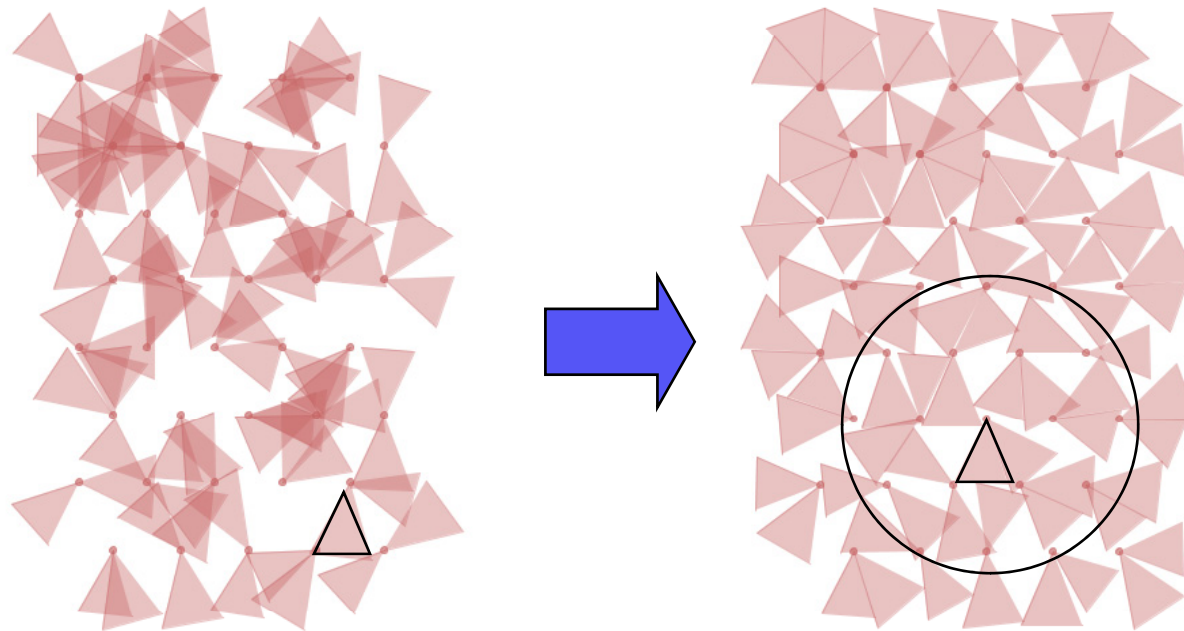

- Computational Geometry problem:
 - How many guards are needed to fully observe an n-walled room?
 - Goal: find an optimal positioning for the guards
 - NP hard problem (Aggarwal, 1984)
 - Art Gallery Theorems and Algorithms (O'Rourke, 1987)

- SC partitioning problem is a derivative of the Art Gallery Problem
 - SCs have **fixed positions** (mobile nodes may be considered in future)
 - Degrees of freedom are **limited to pan/tilt/zoom** capabilities of SCs
 - **Distributed, fault tolerant heuristics**

ROCAS: Simplified field of view of a SC

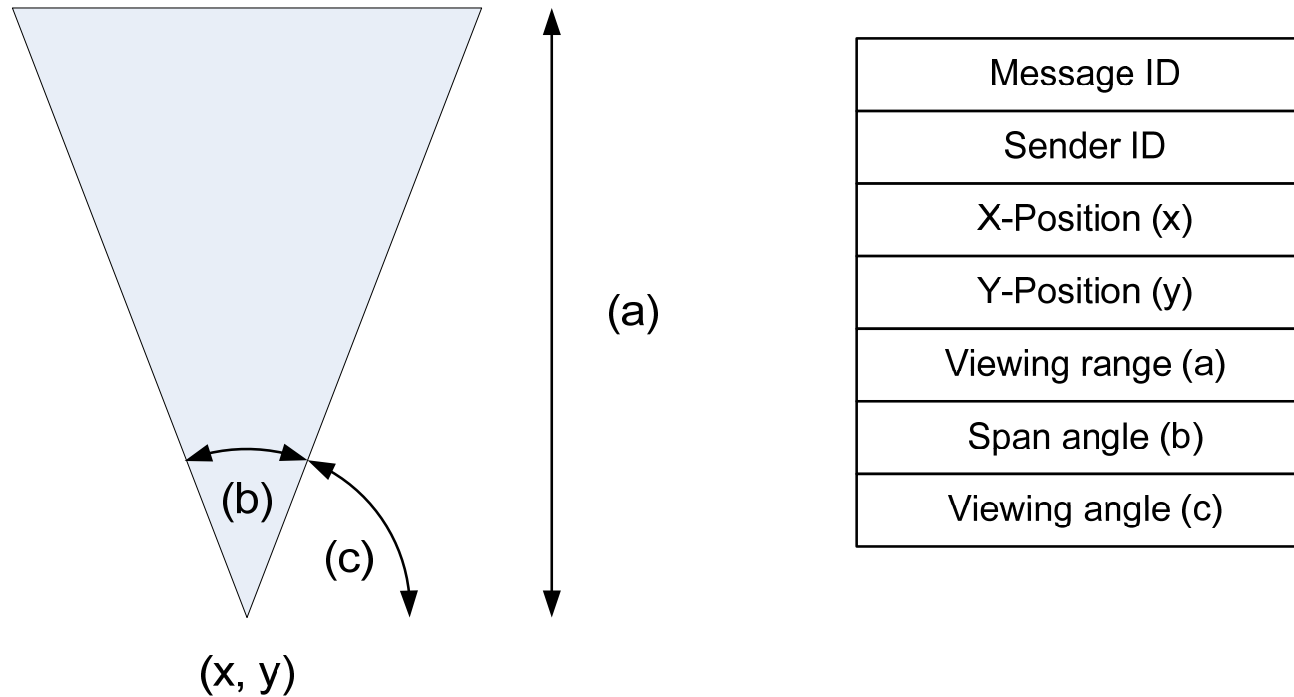

- A SC's field of view and ROCAS **message format**
 - each SC has a fixed position
 - ROCAS changes viewing angle to optimise surveillance coverage

ROCAS Overview

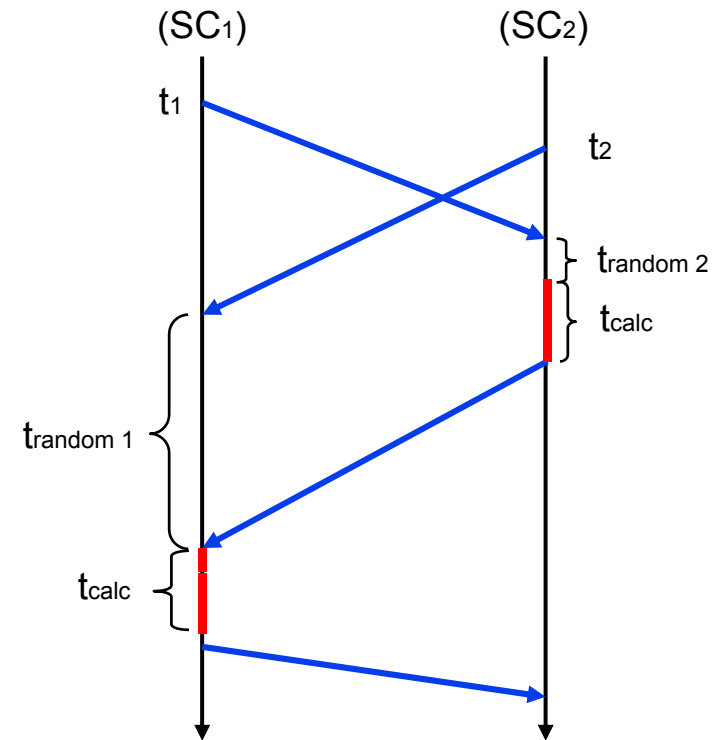
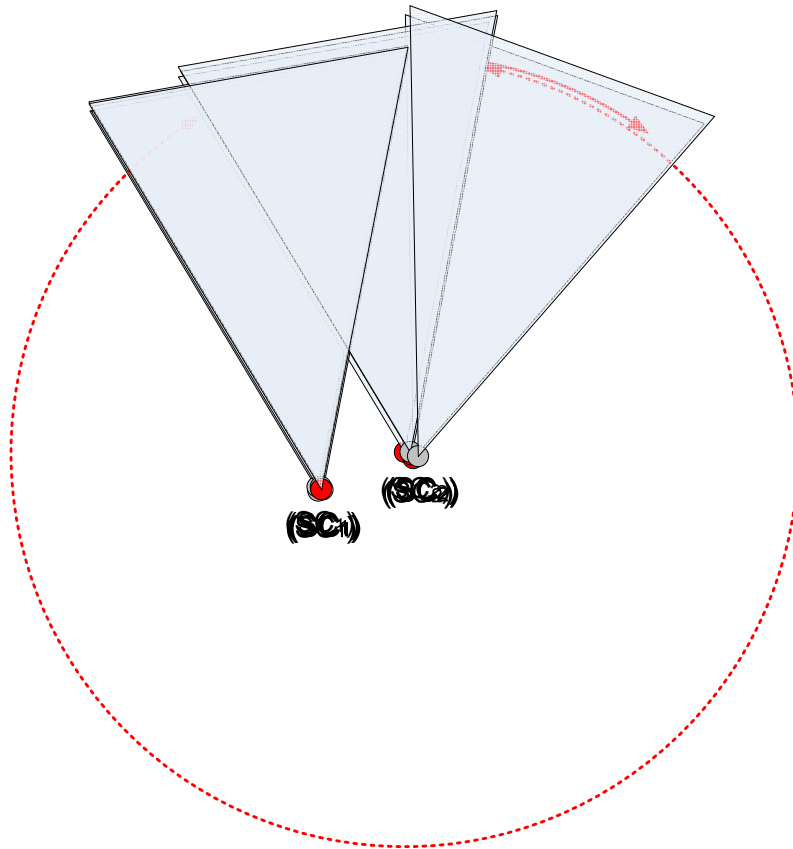

- PC based prototype
 - Use of well known computer vision library OpenCV
 - Motion detection
 - Face detection



- Investigation of **large-scale** networks: simulation used
- Basis: Network simulator **ns2** plus click modular router
- **System parameters**
 - 50 to 350 cameras
 - Area 600m x 600m
 - IEEE 802.11 ad-hoc (160m)
 - Field of view: angle 45 degrees, max. viewing distance: 50m
 - Deployed randomly or on a regular grid
- **Performance metrics**
 - Surveillance coverage
 - Message overhead
 - (Time to termination)

Experiment 1: Increase of Surveillance Coverage

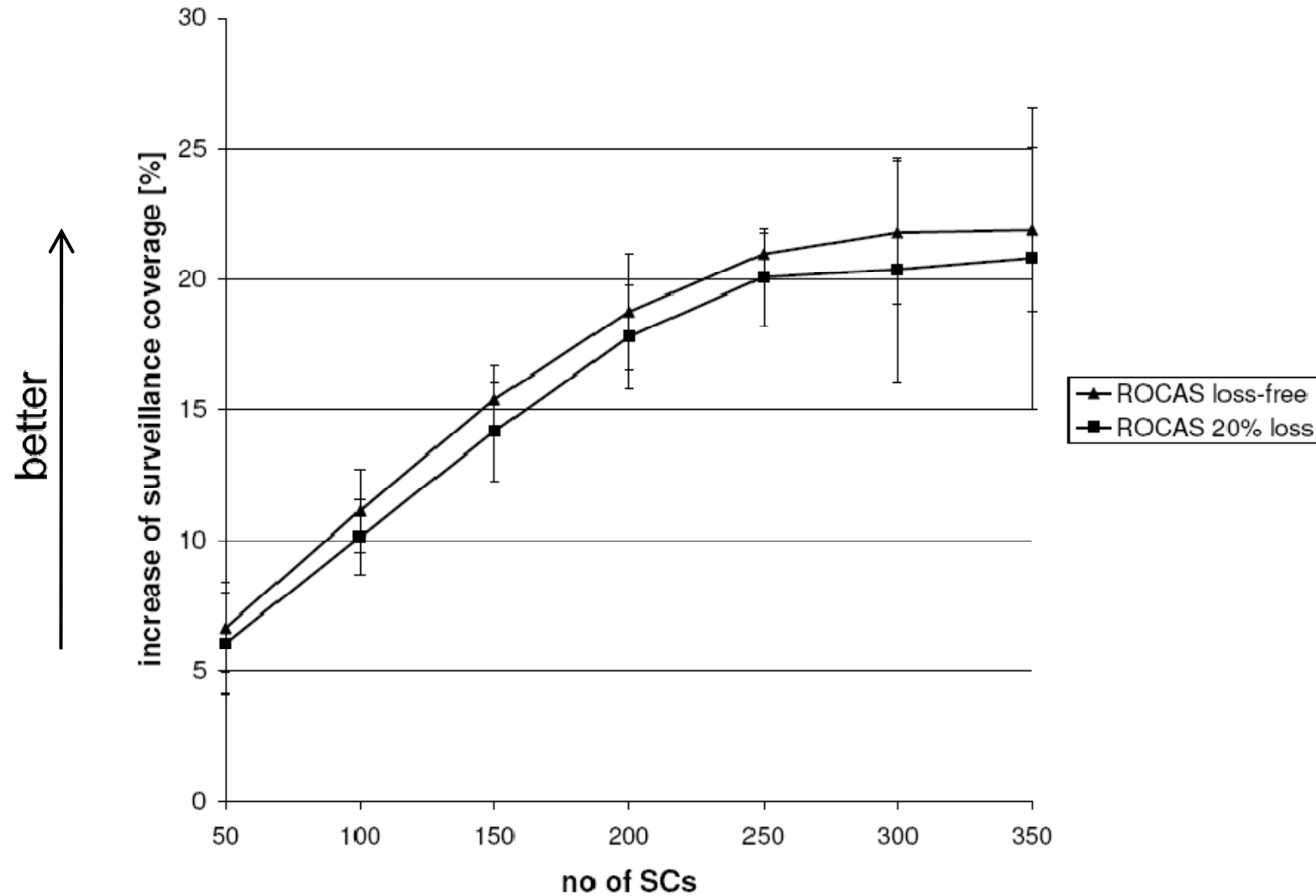

Experiment 2: Fault Tolerance

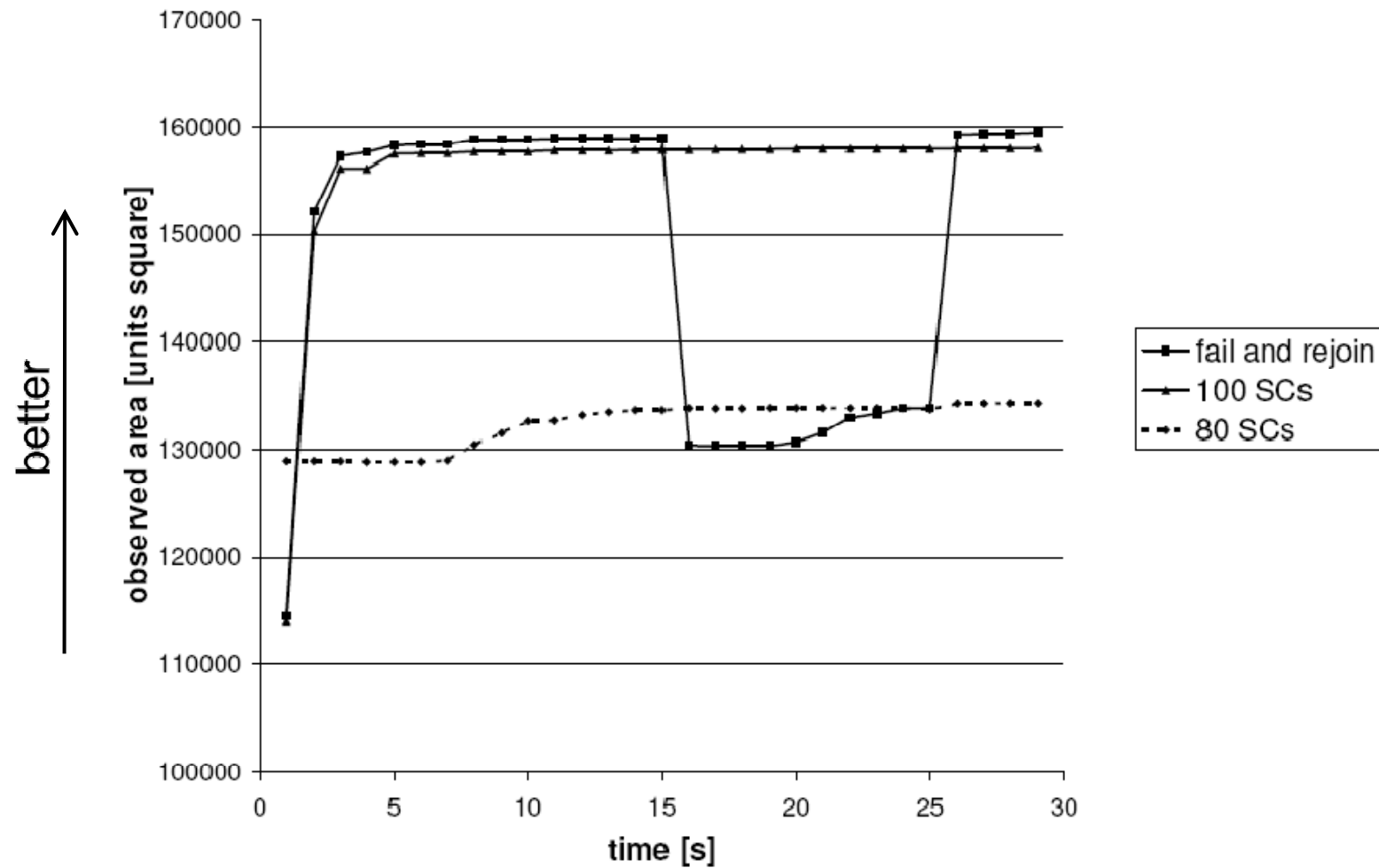

Experiment 3: Message Complexity

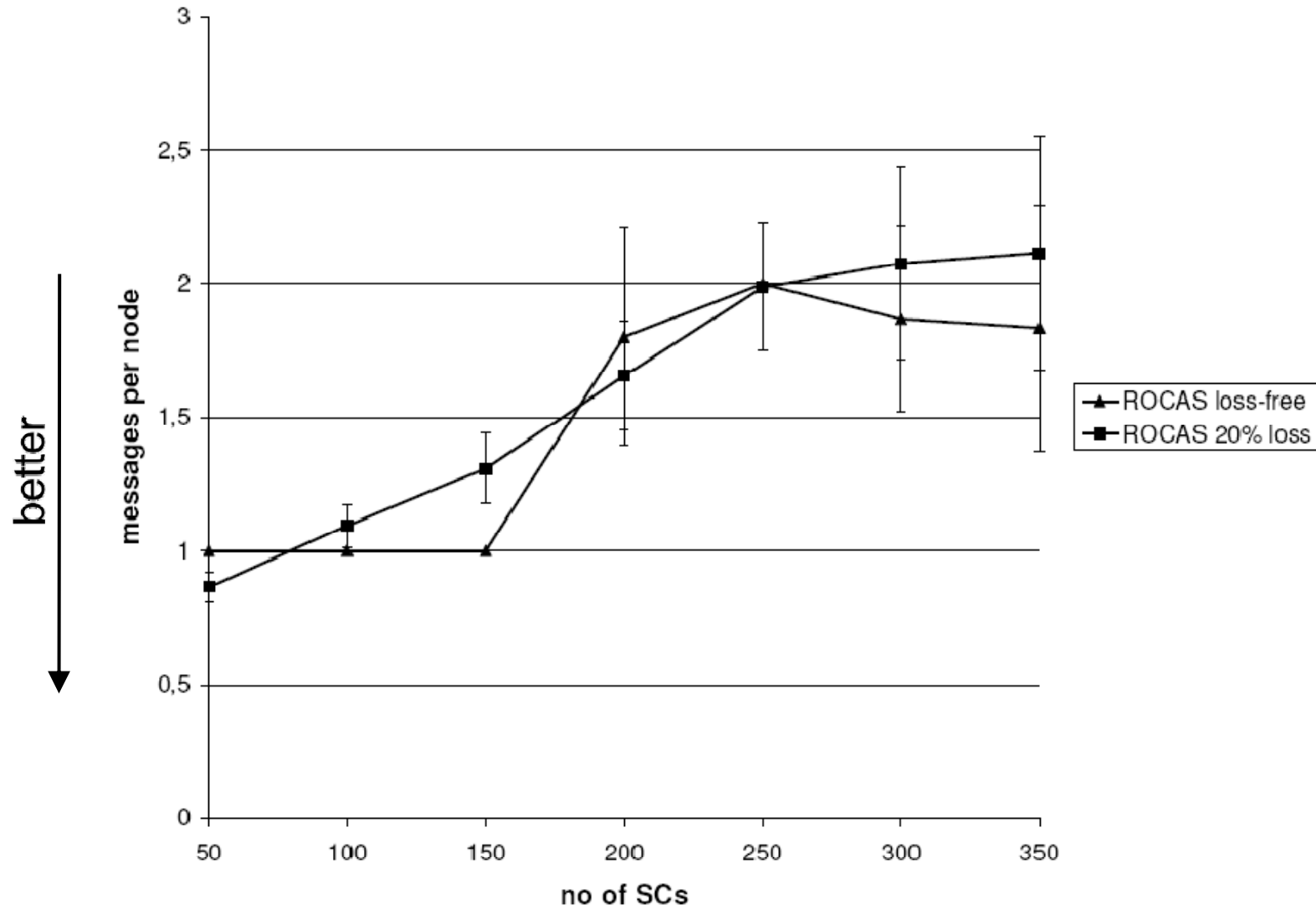

- **Distributed Smart Camera research** includes
 - Computer vision, embedded systems, and system architecture
 - Requires the cooperation between (at least) these fields
- ROCAS enables SCs to **partition an area under surveillance**
 - Example for a distributed coordination algorithm in Smart Camera Systems
 - Scalable (up to 350 SCs per SCSS)
 - Lightweight (message complexity is low)
 - Robust and fault tolerant
- Future prospects
 - Object tracking
 - Demonstrator

Thank you for your attention!

Contact: Jörg Hähner, haehner@sra.uni-hannover.de

Something to read:

- M. Hoffmann, J. Hähner: A Robust Online Algorithm for Spatial Partitioning in Distributed Smart Camera Systems. To appear in Proceedings of the 1st ACM/IEEE International Conference on Distributed Smart Cameras, 2007
- M. Hoffmann, J. Hähner, C. Müller-Schloer: Towards Self-Organising Smart Camera Systems. To appear in: Proceedings of the 21st International Conference on Architecture of Computing Systems (ARCS), 2008